

SAFETY RELAY

AD SR0

INSTALLATION USE AND MAINTENANCE



This symbol indicates an important personal safety warning. Failure to comply with the warning may result in very high risk for exposed personnel.

INTRODUCTION

The AD SR0 is an accessory device for the interconnection of a photoelectric light curtain in a safety circuit. See details below about light curtain models, wiring, etc.



When deciding on the safety category to be adopted, carefully consider the risks analysis of the machine.



The module has been designed in particular for use with the REER light curtains of the Admiral AX, EOS4 (category 4), Vision VX, Vision VXL/MXL, EOS2 (category 2) series. Consult REER before using the interface with other light curtain models or safety devices.



For safe use of the device, it is essential to read and understand the contents of this handbook.



Failure to comply with the prescriptions indicated in this notice may result in very high risks for the operating personnel of the protected machine.

INSTALLATION AND ELECTRICAL CONNECTIONS



Install the AD SR0 safety relay in an environment with a protection rating of at least IP54.



The AD SR0 safety relay must be supplied with a 24Vdc $\pm 20\%$ power supply.



The external power supply must comply with the standard EN 60204-1.

ELECTRICAL CONNECTIONS

The safety relay is equipped with three terminal boards for the connections to the light curtain and to the machine.

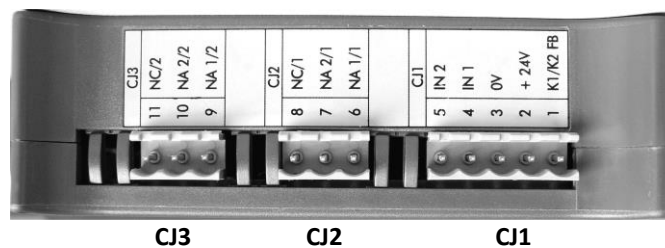

Figure 1

CJ1		
PIN	NAME	DESCRIPTION
1	FB	Internal relays feedback
2	24VDC	24Vdc Power Supply
3	0VDC	0Vdc Power Supply
4	IN2	Light curtain static output
5	IN1	Light curtain static output

CJ2		CJ3	
PIN	NOME	PIN	NOME
6	N.O. contact	9	N.O. contact
7	N.O. contact	10	N.O. contact
8	N.C. contact	11	N.C. contact

Example of connection of the AD SR0 module with JANUS safety light curtain

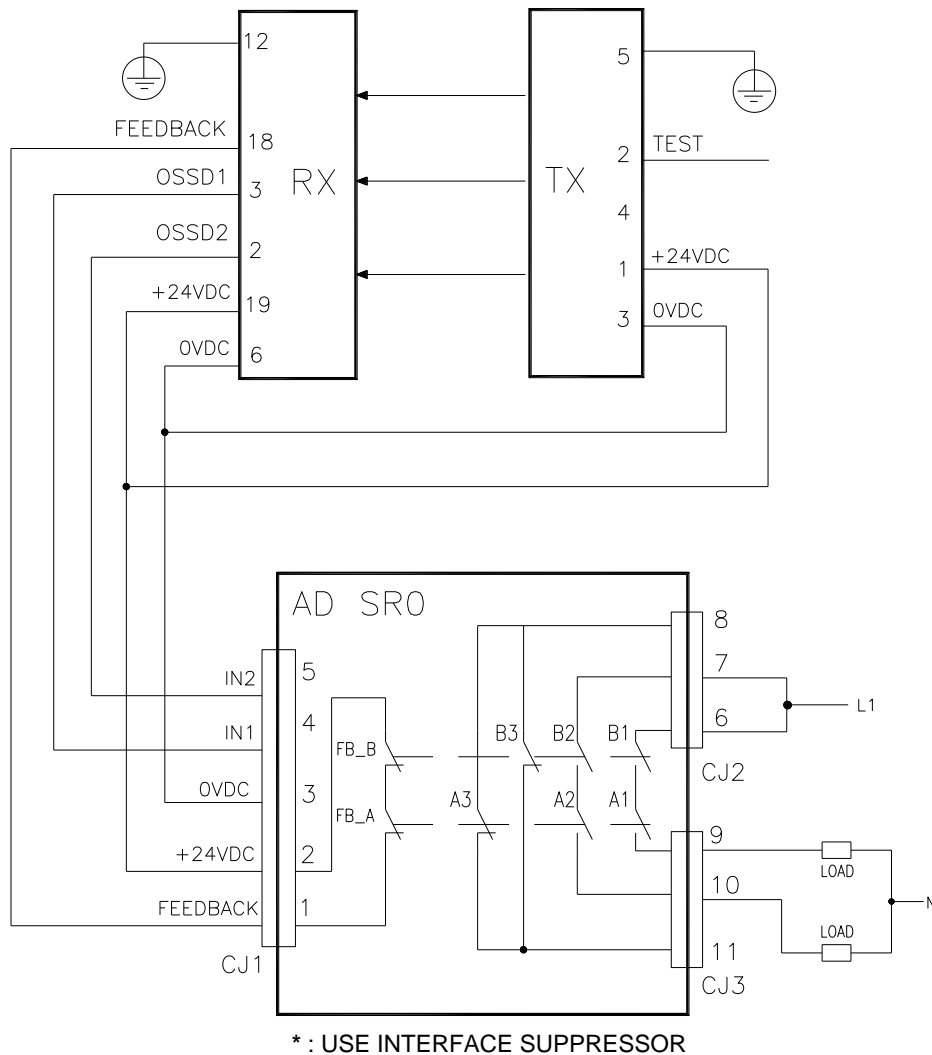
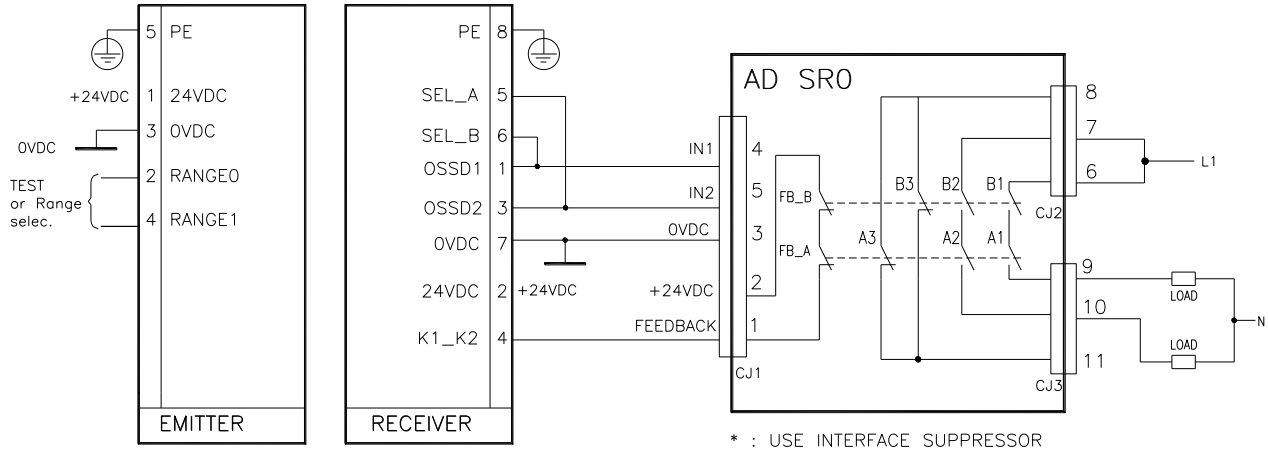
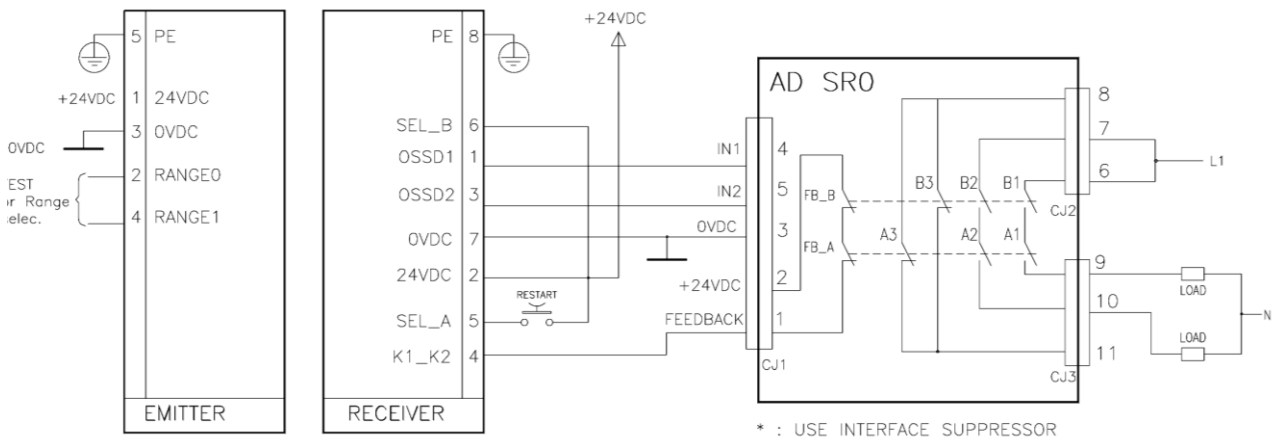

Figure 2

Example of connection of the AD SR0 module with AX / VX / VXL safety light curtain in AUTOMATIC operation mode



Example of connection of the AD SR0 module with AX / VX / VXL safety light curtain in MANUAL operation mode



Connection of VXL Emitter (modification of the above schematics)

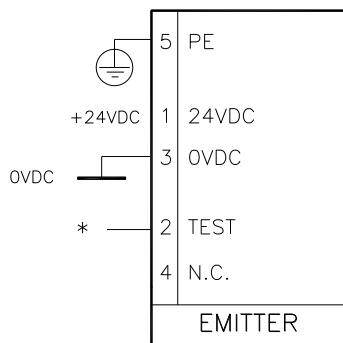

*** If the TEST function is not required by the application, connect pin 2 of the emitter to +24Vdc.**

Example of connection of the AD SR0 module with MXL safety light curtain in AUTOMATIC operation mode

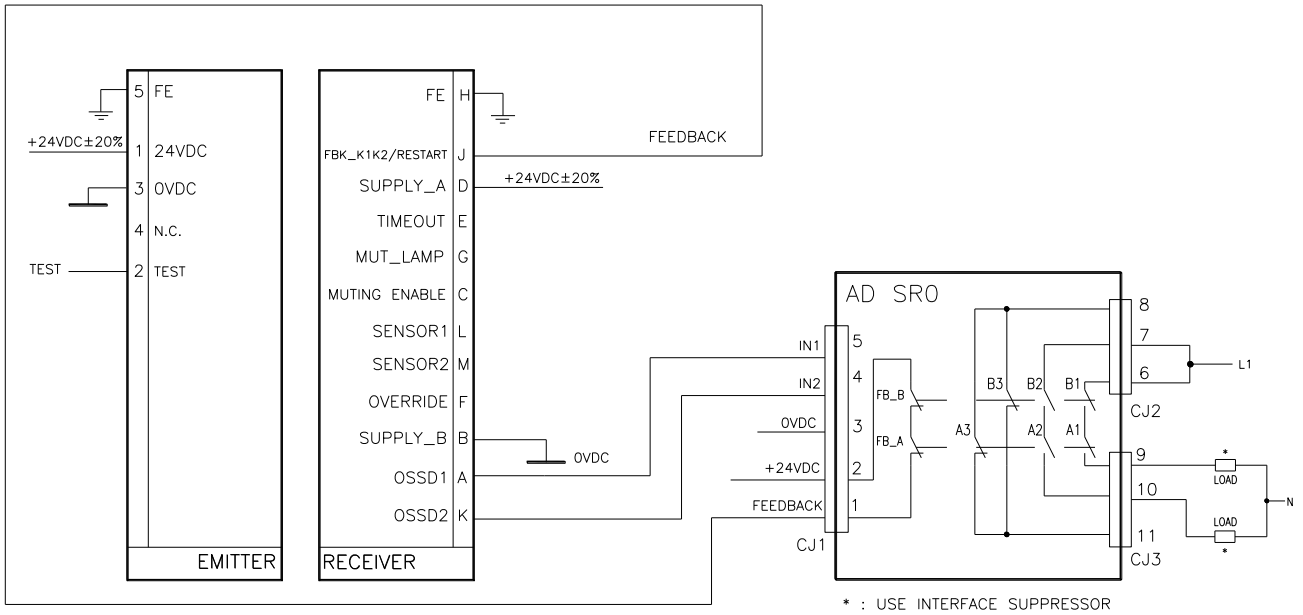

Example of connection of the AD SR0 module with MXL safety light curtain in MANUAL operation mode

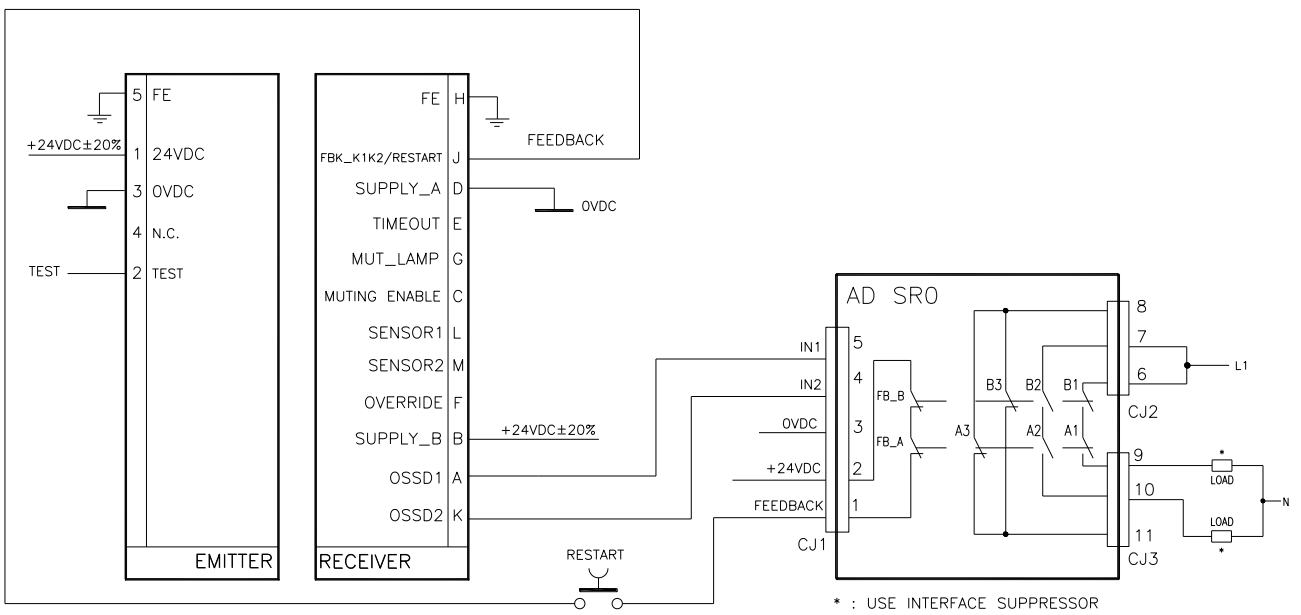

Example of connection of the AD SR0 module with EOS4X safety light curtain in AUTOMATIC operation mode

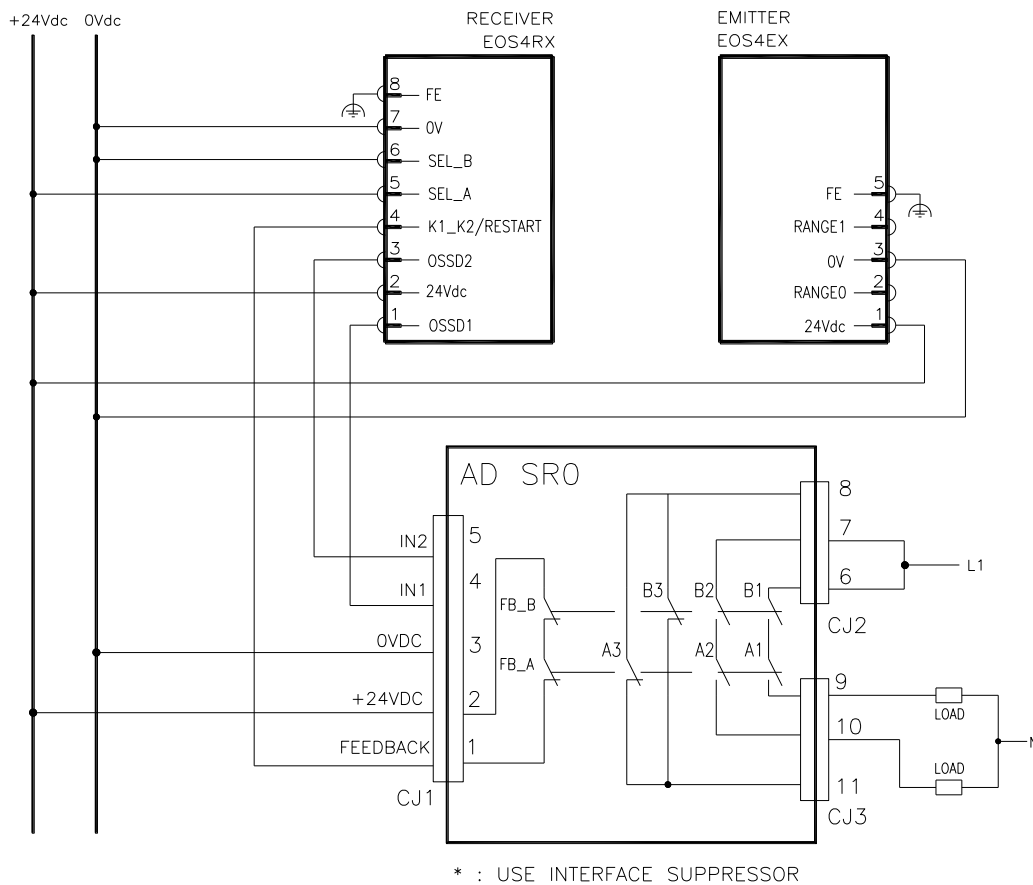

➔ Further details regarding connections can be found on each curtain technical manual.

Characteristics of the output circuit.

For the output circuit, the safety relay uses two guided contact safety relays.

These relays are rated by the manufacturer for voltage and current values above those indicated in the technical data; however, to assure correct insulation and to avoid damage or premature aging, protect each output line with a 3,15A slow-blow fuse and check that load characteristics comply with the indications given in the technical data.

Warnings regarding the connection cables.

- For light curtain/safety interface connections of more than 50m, cables with a cross-section of at least 1mm² must be used.
- It is good practice to separate the power supply of the safety relay from that of other electrical equipment (electrical motors, inverters, frequency variators) or other sources of disturbance.
- The path of the connection cables between the safety relay and the sensors, the connection referring to the feedback contact must be different from that of other power cables.

TECHNICAL DATA

Power supply	Vdc	24 ± 20%
Power requirement	W	1,5 max
Response time	ms	20 max
Connections		Terminal block with protection against reversal of polarity
Max. length of connections	m	100
Operating temperature	°C	0 - 55
Enclosure protection rating		IP 20
Terminal block protection rating		IP 2X
Fastening		Fast attachment to rail according to EN 50022-35
Dimensions (h x w x d)	mm	101 x 35 x 120
Weight	g	180
Output circuit		
Number of contacts		2N.O. - 1N.C.
Max switching voltage		250Vac, 24Vdc
Min switching voltage		10Vac, 10Vdc
Max switching current		2°
Min switching current		10mA@24Vdc
Switching cycles (life)		≥ 50 x 10 ³ (el) / ≥ 40 x 10 ⁶ (mech)

SAFETY DATA											
FEEDBACK CONNECTION ACTIVE						FEEDBACK CONNECTION MISSING					
PFHd	SFF	MTTFd	DCavg			PFHd	SFF	MTTFd	DCavg		
8,16E-09	99,5%	71,02	99,0%	tcycle1	AC15 (3A)	4,60E-07	0,50	71,01738	0	tcycle1	AC15 (3A)
6,77E-10	99,5%	851,50	99,0%	tcycle2		4,42E-09	0,52	851,5035	0	tcycle2	
4,29E-11	99,6%	13442,07	98,9%	tcycle3		9,59E-11	0,69	13442,07	0	tcycle3	
3,25E-09	99,5%	177,52	99,0%	tcycle1	AC15 (1A)	7,74E-08	0,50	177,5234	0	tcycle1	AC15 (1A)
2,71E-10	99,5%	2125,88	99,0%	tcycle2		1,03E-09	0,54	2125,881	0	tcycle2	
1,76E-11	99,7%	32902,00	98,7%	tcycle3		3,55E-11	0,80	32902	0	tcycle3	
2,44E-10	99,5%	2361,50	99,0%	tcycle1	DC13 (2A)	8,82E-10	0,55	2361,498	0	tcycle1	DC13 (2A)
2,10E-11	99,7%	27578,63	98,7%	tcycle2		4,31E-11	0,78	27578,63	0	tcycle2	
1,93E-12	99,9%	306752,23	96,1%	tcycle3		2,64E-12	0,97	306752,2	0	tcycle3	

tcycle1: 300s (one commutation every 5 minutes)

tcycle2: 3600s (one commutation every hour)

tcycle3: one commutation every day

(PFHd according to IEC61508, MTTFd and DCavg according to ISO13849-1)

WARRANTY

ReeR warrants that each AD SR0 unit in new ex-factory condition, in conditions of normal use, is free of defects in the materials and of manufacturing defects for a period of 12 (twelve) months.

In this period, ReeR undertakes to eliminate any faults in the product through repair or replacement of the faulty parts, completely free of charge as regards material and labor.

However, ReeR reserves the right to replace the entire faulty appliance with another equivalent appliance or with the same characteristics instead of repairing this.

Validity of this warranty is regulated by the following conditions:

- The user must inform ReeR of the fault within twelve months from the date of delivery of the product.
- The appliance and its components must be in the conditions in which they were delivered by ReeR.
- The serial numbers must be clearly legible.
- The fault or defect has not been caused directly or indirectly by:
 - Improper use;
 - Non-compliance with instructions for use;
 - Carelessness, inexperience, incorrect maintenance;
 - Repairs, modifications, adaptations not carried out by ReeR personnel, tampering, etc.;
 - Accidents or impacts (also due to transportation or causes of force majeure);
 - Other causes not to be ascribed to ReeR.

Repairs will be carried out at the ReeR laboratories to which the material must be delivered or dispatched: transport risks and the risks of any damage or loss of the material during shipment are the responsibility of the user.

All products and components replaced become the property of ReeR.

ReeR does not recognize any other warranties or rights except for those specifically described above; therefore, no claims for damages may be submitted for expenses, interruption of business or other factors or circumstances in any way related to failure of the product or of one of its parts.

Precise, complete compliance with all the rules, instructions and prohibitions indicated in this handbook is an essential requirement for correct functioning of the safety relay. ReeR s.p.a. therefore declines any responsibility for all and anything resulting from failure to comply, even partially, with such indications.

Characteristics subject to change without notice. • Total or partial reproduction is forbidden without the prior authorization of ReeR.

UKCA DECLARATION OF CONFORMITY

ReeR declares that AD SR0 Safety Relay module complies with following UK legislation:

- S.I. 2008 No. 1597 - The Supply of Machinery (Safety) Regulations
- S.I. 2016 No. 1091 - Electromagnetic Compatibility Regulations
- S.I. 2012 No. 3032 - The Restriction of the Use of Certain Hazardous Substances in Electrical and Electronic Equipment Regulations



Please refer to the link <https://www.reersafety.com/certifications> to download the complete UKCA Declaration of Conformity.



Dichiarazione CE di conformità
EC declaration of conformity

Torino, 07/07/2021

REER SpA
via Carcano 32
10153 – Torino
Italy

dichiara che **AD SR0** e **AD SR0A** sono Interfacce di Sicurezza realizzate in conformità alle seguenti Direttive Europee:

*declares that the **AD SR0** and **AD SR0A**, Safety Interfaces comply with the following European Directives:*

- **2006/42/EC** "Direttiva Macchine"
"Machine Directive"
- **2014/30/EU** "Direttiva Compatibilità Elettromagnetica"
"Electromagnetic Compatibility Directive"
- **2011/65/EU** "Restrizione dell'uso di determinate sostanze pericolose nelle apparecchiature elettriche ed elettroniche"
"Restriction of the use of certain hazardous substances in Electrical and Electronic Equipment"

e alle seguenti Norme: */and to the following Standards:*

- **EN 55032: 2015**

Carlo Pautasso
Direttore Tecnico
Technical Director



Simone Scaravelli
Amministratore Delegato
Managing Director

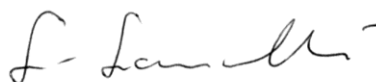



Via Carcano, 32
10153 Torino, Italy
T +39 011 248 2215
F +39 011 859 867
www.reersafety.com
info@reer.it



All REER product manuals are available at URL